

Bench TG0850

The TGO Bench is more than just any old abs bench. This is a classic example of how TGO have brought their fitness and design expertise to get the most out of a single unit. There are a number of exercise variations on this piece of equipment, not just limited to sit ups. The bars around the edge enables the user to perform incline and declined press ups, as well as tricep dips. The bench also caters for a wide variety of sit up and abdominal crunch exercises.

Specification

1. 100% Made in Britain
2. Certified to EN16630, (legacy standards, BSI PAS888 - safety compliant for ALL ages, users and non-users & DIN79000 - safety compliant for users, aged 14+). All TGO outdoor gym equipment is free from exposed end stops, entrapments, sharp edges and crush points

ALWAYS ASK FOR EN16630 FOR OUTDOOR GYMS

3. Great instructional signage- workout QR code videos, start and finish diagrams.
4. Weatherproof
5. Resistance-based equipment - no electricity required
6. Low maintenance
7. Designs include key elements of Inclusive Fitness Initiative guidelines
8. TGO plant a tree in the NHS Forest for every piece of equipment sold
9. Anti vandal fixings
10. Available in all major RAL colours
11. Stop mechanisms concealed
12. Paint UV stabilised
13. Welds certified to EN15015614
14. Powder coated finish
15. Separate ground anchor for future upgrades

The bench allows the user to produce sit ups, dips and inclined push ups. These are detailed on the instructional signage

TG0951UK

Integrated instructional signage and QR codes to view how to use videos. Coming soon!

Guarantees

25 years steel work
2 years bearings
5 years paint



EN
16630



25 YEAR
WARRANTY

MADE IN
BRITAIN



Bench TG0850

Production Details

Manufacturer Standard: EN16630 (legacy standards - PAS888, Din79000)
 Framework: Mild Steel Grade S275 (min 3mm thick)
 Finish: High quality gloss finish polyester powder coat paint
 Signage: High quality reverse printed PETG (Integrated coming soon)
 Backs: Enhanced Polyphenylene Ether (PPE) Resin

Enhanced Corrosion Protection

An enhanced corrosion protection is available on request for this product. Hot dip galvanising is the process TGO use to add a protective coating to the body of our products on our equipment in coastal areas, which have higher air salinity or in harsh urban and industrial atmospheres with higher sulphur dioxide pollution*.

The upgrade includes:

- Upgrading to hot dip galvanising
- Fixings are upgraded from A2 to A4 stainless steel

*An upgrade to galvanised steel will be necessary for the warranty in these environments.

Installation

This product is installed onto a generic TGO Large Ground Anchor. Please see the 'TGO Installation & Assembly Guidelines' for guidance on installing this anchor. Please refer to the diagram opposite for safety spacing (green outline)

Safety

This product requires 1.5m of clear space around the equipment (green outline).

- Fall height: 0.52m
- Clear Space: 17m²

There is no safer surface requirement and therefore TGO only recommend a minimal surface area (grey outline).

Parts List

No	Part	Dimensions	Weight	Qty
1	The Bench	L1821, W426, H652	57 kg	1
2	Large Anchor ⁺	L777, W489, H344	23 kg	1

⁺Substituted with 6x HILTI fixings for surface mounted option

Clear Space Required Recommended Surfacing Base Plate & Centre Lines
 (25mm tolerance added in each direction)

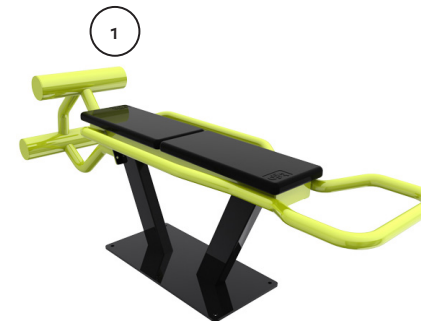
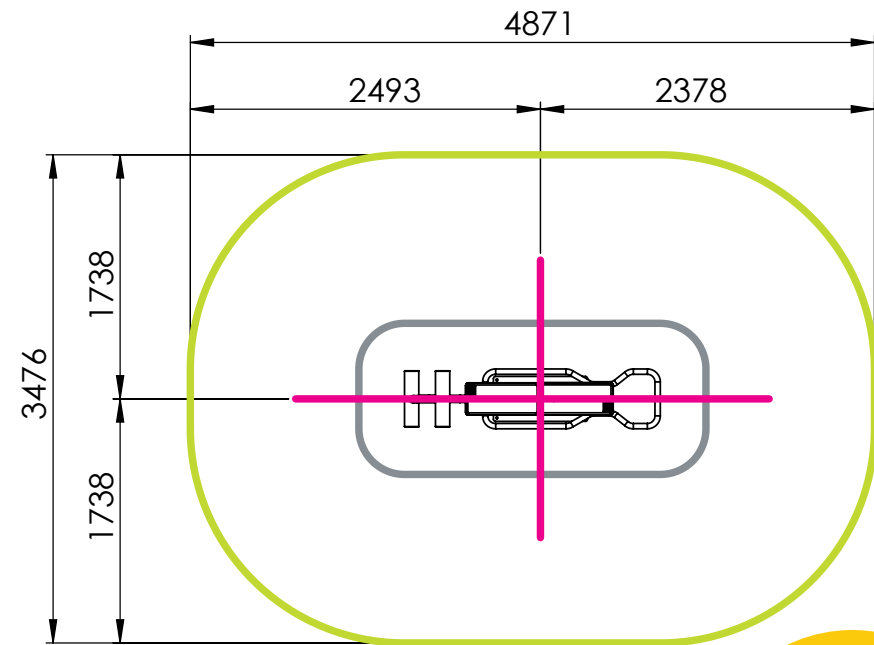

Ground anchor is separate, makes future upgrades easy!

