

# Cross trainer

## TG0861

On this stylish Cross Trainer, the user will feel like they are in an indoor gym but outside! The Cross Trainer is designed to give a cardiovascular workout, as well as improving muscle tone in the legs and arms. With top quality bearings and sliding mechanisms the TGO Cross Trainer is smooth, safe and easy to use. From the super-fit to those new to exercise, this is the perfect piece for any gym. It is also available in the TGO mini range and if you want to charge your phone whilst exercising, the TGO Cross Trainer is also available in Cardio Charge (see TGO862). Generate electricity whilst exercising and charge your mobile phone or tablet as the same time. People Power!

### Specification

1. 100% Made in Britain
2. Certified to EN16630, (legacy standards, BSI PAS888 - safety compliant for ALL ages, users and non-users & DIN79000 - safety compliant for users, aged 14+). All TGO outdoor gym equipment is free from exposed end stops, entrapments, sharp edges and crush points

**ALWAYS ASK FOR EN16630 FOR OUTDOOR GYMS**

3. Great instructional signage- workout QR code videos, start and finish diagrams.
4. Weatherproof
5. Resistance-based equipment - no electricity required
6. Low maintenance
7. Designs include key elements of Inclusive Fitness Initiative guidelines
8. TGO plant a tree in the NHS Forest for every piece of equipment sold
9. Anti vandal fixings
10. Available in all major RAL colours
11. Stop mechanisms concealed
12. Paint UV stabilised
13. Welds certified to EN15015614
14. Powder coated finish
15. Separate ground anchor for future upgrades

NEW stainless steel handles with 80mm end caps to conform to all international safety standards

The foot plates themselves have a tread plate for secure grip and a food guard to avoid any slipping. The bases on the foot plates are shaped to avoid any potential entrapment between it and the ground.

Suggested user age group 11+

The joint between the foot plates and the handles is designed to never protrude at the front of the machine to make sure no passer-by is in danger of getting hit by a moving part

### Guarantees

25 years steel work  
2 years bearings  
5 years paint

All the mechanisms are internal to the main chassis. They are covered by the top and side panels and a clever rotating disc on each side. This ensures there is no opportunity for any entrapments or protruding moving parts that could hit non-users

**TG0861UK**  
Integrated instructional signage and QR codes to view how to use videos. Mounted onto the vertical post



EN 16630



25 YEAR WARRANTY

**MADE IN BRITAIN**



# Cross trainer

## TG0861

### Production Details

Manufacturer Standard: EN16630 (legacy standards - PAS888, Din79000)  
 Framework: Mild Steel Grade S275 (min 3mm thick)  
 Finish: High quality gloss finish polyester powder coat paint  
 Signage Plate: High quality reverse printed PETG

### Enhanced Corrosion Protection

An enhanced corrosion protection is available on request for this product. Hot dip galvanising is the process TGO use to add a protective coating to the body of our products on our equipment in coastal areas, which have higher air salinity or in harsh urban and industrial atmospheres with higher sulphur dioxide pollution\*.

The upgrade includes:

- Upgrading to hot dip galvanising
- Fixings are upgraded from A2 to A4 stainless steel

\*An upgrade to galvanised steel will be necessary for the warranty in these environments.

### Installation

This product is installed onto a generic TGO Large Ground Anchor. Please see the 'TGOGC Installation & Assembly Guidelines' for guidance on installing this anchor. Please refer to the diagram opposite for safety spacing.

### Safety

This product requires 1.5m of clear space around the equipment (green outline).

- Falling height: 0.36m
- Clear Space: 15.1m<sup>2</sup>

There is no safer surface requirement and therefore TGO only recommend a minimal surface area (grey outline).

## Parts List

No	Part	Dimensions	Weight	Qty
1	Cross Trainer*	L1182, W523, H1610	108 kg	1
2	Large Anchor <sup>+</sup>	L777, W489, H344	23 kg	1

\*Based on the greatest value position

<sup>+</sup>Substituted with 6x HILTI fixings for surface mounted option

Clear Space Required  Recommended Surfacing  Base Plate & Centre Lines   
 (25mm tolerance added in each direction)

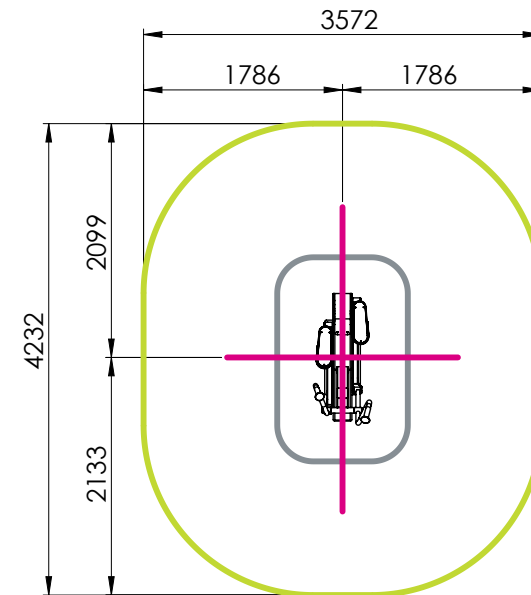

Ground anchor is separate, makes future upgrades easy!

